

10-65 TONS

# Forklifts for Your World



The environments, climate challenges, drivers' needs, lifting loads and heights of every lift truck driver are always different and special. By listening and observing carefully to learn about your world, it's possible to design and deliver the most ideal lift truck for your operation.

## YOUR WORLD

**"The hardest part of my job is working outside. Rain, wind and snow can make weather conditions hard."**

**Olavur Jacobsen  
Faroe Ship, Faroe Islands**



## Built for your world

Here's a secret we know and understand: we all like to talk about ourselves, but the world that matters most to you is your world, not ours. We at Konecranes Lift Trucks listen to, learn from, design for, deliver to and support you to help you succeed in the unique world where you work.

### Continuous improvement

Our mission is to build and customize the hardest-working, longest-lasting, heavy-duty lift trucks for our customers' worlds. This has been our way ever since we made our very first lift truck in 1959 for a very special customer, and our customers still provide the most important input for the continuous improvement of our lift trucks.

### Quality in every aspect

Excellence is a cornerstone of the Konecranes product design process and a hallmark of the Konecranes brand.

Excellence shows in our heavy-duty durability, modern cabin and all the little things that makes up the efficient, high-quality lift trucks that we proudly produce every day.

Every lift truck goes through rigorous tests before delivery to check that your equipment always meets the highest possible product standards.



## First in safety

When working with material handling and heavy loads, you want to minimize safety risks to help maintain the well-being of your employees. You can do this by implementing new and improved preventive safety measures.

### YOUR WORLD

Innovations like Work Zone geofencing and Konecranes weight verification system are not important because they are cutting-edge, but because they make your work environment safer. They protect your drivers and ground staff.

## Safety-first culture

We think that the pursuit of safety never stops. It's not about built-in safety features alone – it's about preventive maintenance, training and building a safety-first working culture. Konecranes is often the first to introduce new technology that improves safety.

Safety is in everything we do, all the way from R&D to all the customization possibilities and technological innovations we offer. Depending on your particular operations, we can meet your specific needs with a wide variety of preventive solutions to maximize the safety of your personnel.

Konecranes digital services has received ISO/IEC 27001:2013 certification for information security management. Secure software development practices ensure security risks are considered in each phase of the software development lifecycle. This helps developers to build highly secure applications and ensure that risks and possible vulnerabilities are captured in the development, and not in the production.

### Technology for safe operations

Our overload detection system helps prevent accidents by sending data on the use of each of your forklifts for checking and analysis.

At Konecranes, the TRUCONNECT® Remote Monitoring service receives that data and can send alert notifications of overloads and overrides to designated personnel at your own facility.

Container weighing detects dangerous overweight conditions with accurate weight measurement to meet all local requirements for maritime and port safety.

### Work Zone for safer operations

Developed by Konecranes, Work Zone is a suite of location-based services designed to improve the safety of lift truck operations, especially in busy, high-traffic environments.

Work Zone uses GPS technology to create geofencing – invisible fences around real-world areas. You can remotely control lift trucks and their height limitations, speed limits and other safety matters inside computer-defined areas – virtual fences. Drivers can see selected alerts on their operating display and you can also send the alerts by SMS or email to chosen recipients.





## Customization

Every operation must meet different challenges. Lift trucks need to be able to function anywhere from the blazing deserts of the Sahara to the frozen wastes of the Arctic. With optimal performance and the right combination of features and attachments, Konecranes forklifts can help you maximize your operational efficiency.

### YOUR WORLD

**“Conditions in the production of sand-lime bricks are tough: there are heavy loads to be transported and there’s a lot of dust. There are also a lot of vehicles and workers moving around in the plant. Lift trucks must be able to cope in the rough environment.”**

**Heidelberger  
Kalksandstein GmbH**

## Everything is possible

Listening to our customers and meeting their needs has been our way from the very start. Not only do we want to help you to lift loads, but we also want to help lift our customers’ businesses. So we listen, learn and develop our products based on customer experience.

You provide us with the details of your operational needs and goals, and we design a lift truck that meets your expectations and more.

The strength, performance and reliability of every Konecranes lift truck are based on the heart of our technology: a strong box-type chassis, efficient load-sensing hydraulics and intelligent electronic machine control (EMC) that monitors the lift truck’s vital components and functions. Our tight organization and a close dialogue between sales and engineering ensure that we can provide for your customization needs in the best way possible.

### EXAMPLES OF CUSTOMIZED FORKLIFT SOLUTION

- SMV 22-1200 C, equipped with 5000 mm-wide carriage and three 4000 mm forks
- SMV 25-1200 C, with sideshifting carriage, fenders prepared for snow chains, steel grating protection on roof and front windows, and electric cabin tilting pump
- SMV 60-1500 C with special carriage and 7 forks for handling steel

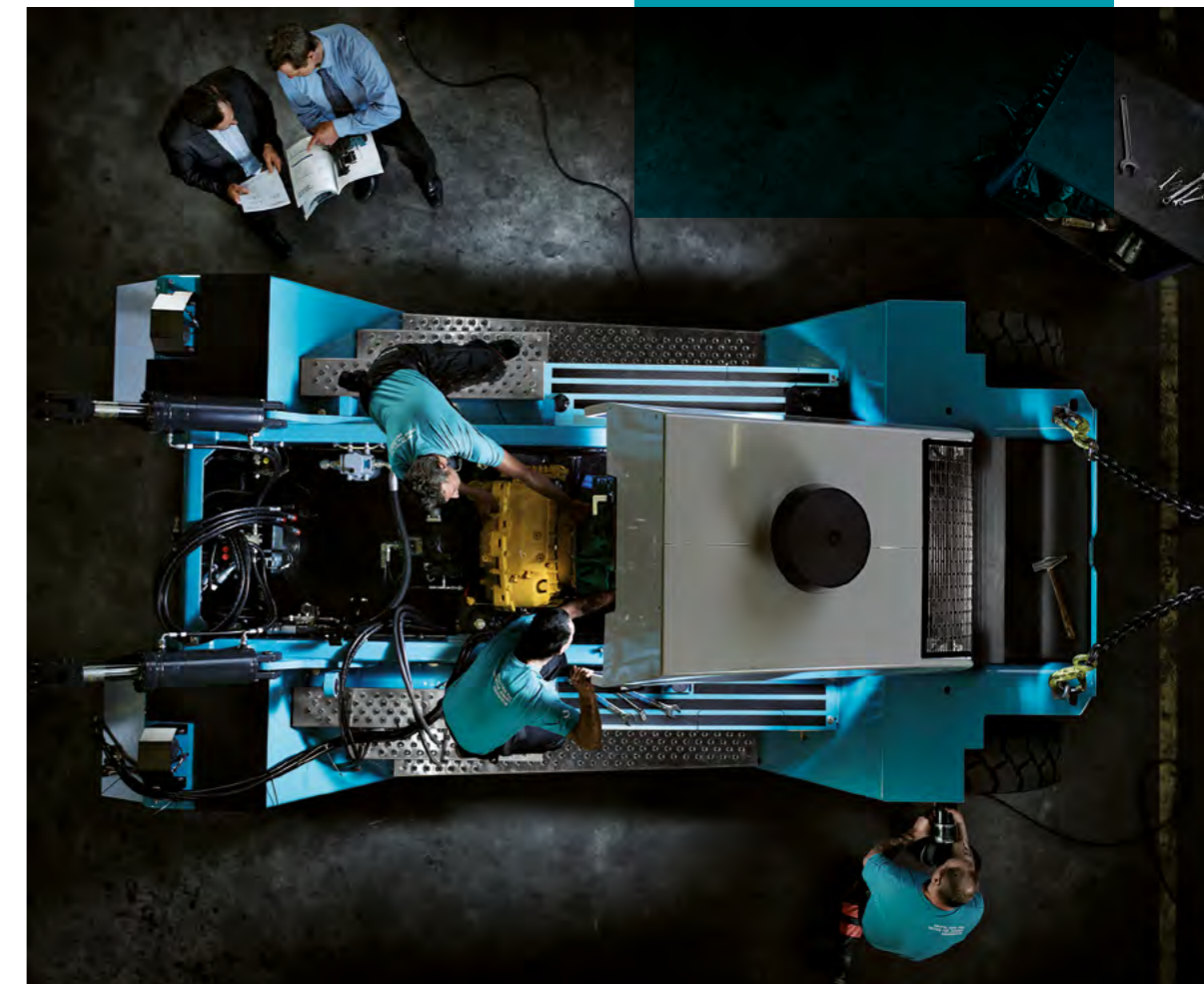



## Customized stone stack gripper for safe loading

Heidelberger Kalksandstein GmbH, with its headquarters in Durmersheim, Baden Württemberg, specializes in the production, support, and distribution of the popular construction material sand-lime brick. The company has 200 employees and seven plants in Germany, as well as one in Switzerland.

### CUSTOMER STORY:

**NAME:**  
Heidelberger  
Kalksandstein GMBH

**INDUSTRY:**  
Building materials

**COUNTRY:**  
Germany

"The heavy-duty lift trucks that Konecranes has made for us can easily handle the rough, dusty and high-traffic environment at our plant and take the stone packages gently and safely to their destination."

Heidelberger  
Kalksandstein GmbH

### Sensitive handling

Conditions at the Heidelberger Kalksandstein plant in Kronau are rough. Finished stone packages must be transported within the plant – a task that requires robust and sensitive heavy-duty lift trucks.

The forklifts on the job must be able to withstand the tough conditions of stone production and at the same time, ensure that the stone packages travel safely from production to the warehouse and to the delivery truck. The driver should also be safe and comfortable whenever operating the vehicle.

### Special tools for secure grip

Konecranes Lift Trucks designed two heavy-duty forklifts specifically for Heidelberger Kalksandstein. They added stone stack grippers from SH Anbaugeräte, special tools that hold stone packages in a secure grip and are large enough to grab several palettes at the same time.

The forklifts on the job SMV 12-1200 C forklifts are the first of the C series to be fitted with a stone stack gripper. Their lifting height is more than 6.5 meters and their bearing capacity is up to 8 tonnes.

### Outstanding loading and ergonomics for drivers

These robust, hard-working forklifts move the sand-lime bricks around the plant safely. Drivers can load and unload with very high precision.

The gripper is so wide, it can pick up five palettes of bricks at the same time.

The special forklifts are also equipped with an electronic control system and the Konecranes Lift Trucks OPTIMA cabin. This cabin dampens noise and vibration, and includes air conditioning, a strutless windscreen, a DAB radio, and a 7-inch touch monitor. It offers drivers a high level of comfort, a clear overview of their vehicle and optional joystick control.

In the interests of safety, electronic sensors keep the driver informed about the hydraulic clamp pressure. In addition, these special forklifts are restricted to a maximum speed of 12 kilometers per hour.



## The Lifetime Advantage

Owning the perfect lift truck is not only about the machine itself. It's about maintaining high performance as the years go by, with services such as quality spare parts, preventive maintenance, support when you need it, or tailored training for in-house mechanics.

### YOUR WORLD

**"The machines from Konecranes are very reliable and good quality, which is very important for us living in the middle of nowhere here in the Faroe Islands. Only the best of the best is useful for us. And if necessary, we can always call for help, day and night and get the support we need."**

**Johann Behrens  
Fleet Manager  
Faroe Ship, Faroe Islands**

## Smart Connected Lift Trucks

Konecranes Smart Connected Lift Trucks is a range of remote service applications that track the real usage and conditions of your lift trucks in real time, allowing you to use insights from this data to optimize the productivity of your operation. For example, you can better forecast and schedule estimated maintenance, discover and improve weaknesses in safety and efficiency, or enhance driver performance by identifying training needs for more economical and ecological driving.

### Listening to your lift truck

Is your maintenance at regular intervals, or do you plan it based on your actual needs? Do you order spare parts after a breakdown, or do you get them before they are needed? Do you know how your lift trucks are doing, or are you still guessing?

Knowledge is power, and when it comes to taking expert care of your lift truck, nothing beats knowing what will happen before it happens. So, what do your Smart Connected Lift Trucks want to tell you today?

### Expert support when you need it

We have a unique service concept in the lift truck industry. It provides you with a seamless service experience, starting with the condition of the forklift, and producing all needed parts and work orders.

Being a global company, Konecranes is at the center of a huge network of service and distribution partners around the world. Our expert support helps you to maintain extended use cycles and give your equipment a longer lifetime. We also offer several related services, such as upgrades, safety and maintenance kits, e-learning platforms, recommended parts lists and more.

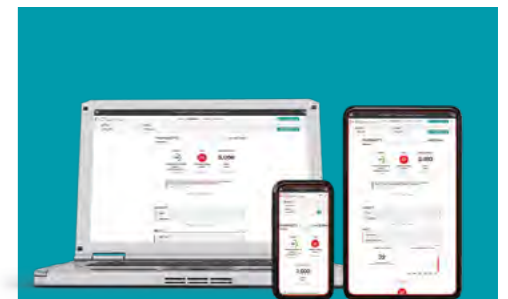

### YOUR WORLD

**"I can sit at my desk and check the status of all our trucks – how they are doing and how they are being used."**

**Rolf Andersén  
Gränges, Sweden**





## Eco-efficiency

To be able to make choices for a better tomorrow, you must find new ways to reduce costs without compromising performance. With the optimal combination of features and attachments, you can help protect the environment and still maximize your operational efficiency.

### YOUR WORLD

Product advances like Konecranes Ecolifting can make a big difference in operating costs without any decrease in performance.

## Konecranes Ecolifting

Developing environmental solutions has been important to us for a very long time. We give you the opportunity to simultaneously save money and help the environment by using less fossil fuels.

Konecranes Ecolifting is a future-proof concept with new solutions continuously in development. In all of our products, true value lies in the small and intelligent details implemented with cutting-edge technology that make Konecranes Lift Trucks some of the world's most advanced in the industry. Small things make a huge difference.

Konecranes forklifts are currently available in two Ecolifting models: Power Drive and E-VER. The Power Drive helps you to reduce fuel consumption and carbon emissions without compromising performance. The E-VER is a fully-electrified lift truck with zero fossil fuels, no emissions from the engine or battery, and very low noise levels.

**KONECRANES**  
ecolifting™

### POWER DRIVE

- reduce fuel consumption and emissions by up to 15%
- minimal capital investment with payback in less than a year
- same performance, less fuel consumption

### KONECRANES E-VER

- no emissions from the machine
- superior driving experience
- easy maintenance
- for both indoor and outdoor use
- fast charging



# Driver-friendliness

For the driver spending countless hours in a lift truck, the most important thing is not the return on investment or the overall performance of the fleet. Drivers want to feel secure and comfortable, and have the opportunity to do their jobs with precision and effectiveness.

## FEATURES FOR DRIVER-FRIENDLY OPERATIONS

### CURVED GLASS GIVES REMARKABLE VISIBILITY

Drivers have an exceptional range of vision through very large, lowered windows with no corner posts, a thin but very strong roof crossmember, and curved panels.

### OUTSTANDING ERGONOMICS

With driver-focused design, the OPTIMA cabin is one of the most spacious on the market. Everything is within easy reach.

## YOUR WORLD

People are your most valuable asset. Driver-friendly trucks facilitate the well-being and work of the drivers.

Cabins that are well-designed for long shifts and demanding conditions lead to relaxed and more effective drivers. Konecranes cabins put your drivers in a position to succeed – to be their best at what they do.

### THE RIGHT TRUCK FOR YOUR OPERATION

Select the right lifting mast from our wide range. Choose between Duplex (with or without free lift) and Triplex (with free lift).

### ELECTRONIC MACHINE CONTROL, EMC MASTER

Full monitoring of all vital components and functions on a 7" touch screen. Programmable settings. CanBus technology increases engine and transmission reliability as well as hydraulics and levers.

### SMART LOAD-SENSING HYDRAULICS

Specially designed hydraulics sense the weight of the load and adapt lifting power accordingly. The truck provides maximum power only when really needed, so it consumes less fuel while reducing emissions and noise.

### QUICK-CHANGE FORK SYSTEM

Choose the right equipment from different forks, coil rams, and other lifting attachments.



# Meeting the needs of drivers

Cabin OPTIMA, designed and built by Konecranes Lift Trucks, offers comfort and superior visibility for your drivers. Both the cabin and the truck itself can be customized to fit your specific needs, so all of your operations on the ground can run safely and smoothly.

### Ergonomically advanced

Instrumentation is conveniently accessible to the right of and above the driver, improving driver posture and positioning during operation. If you need it, ask us to install extra equipment and add the controls as part of the instrumentation layout.

### Solutions for comfort

An excellent seat with compressor suspension, cabin heating and ventilation, air conditioning – we provide your drivers with every possible comfort. Optional ergonomic steering solutions improve your drivers' productivity.

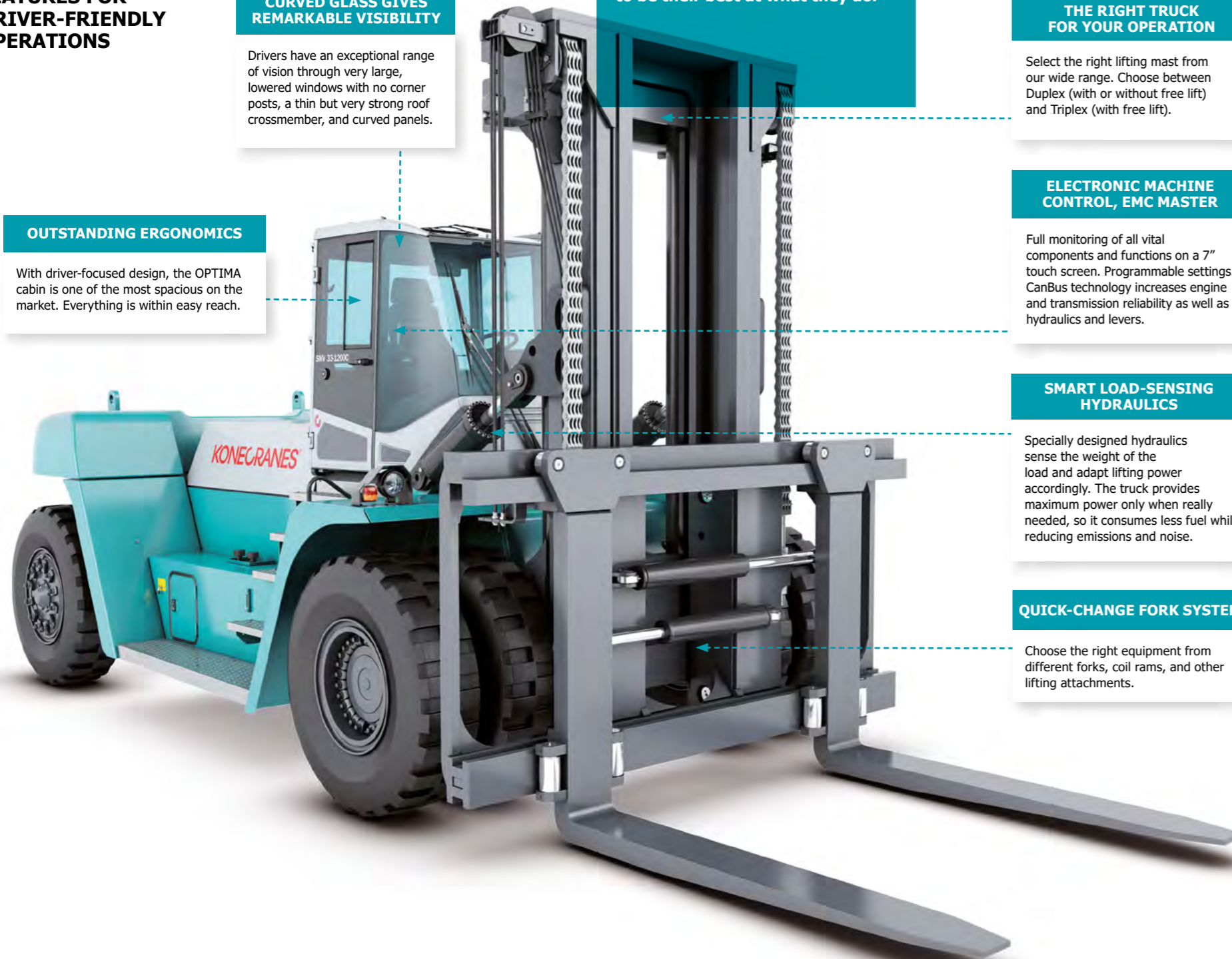



WHAT DO YOU NEED TO LIFT?

# We have the attachment

You'll find your lifting solution in our complete range of lifting masts, fork/carriage combinations, fork/shaft systems, and attachments. This is just a sample of what we offer – ask us about what you need if you don't see it here.



## FORK AND CARRIAGE COMBINATIONS



Duplex, 2-stage, no freelif



Duplex, 2-stage with freelif



Triplex, 3-stage with freelif

## FORK AND CARRIAGE COMBINATIONS



Standard carriage with integrated forks, sideshift, and fork positioning



Carriage with kissing forks for steel handling



Carriage with reinforced forks for round cargo



Carriage with one leveling fork (up/down) for sensitive cargo like sawmill products



Carriage with center leveling (2 forks) for sensitive cargo



Carriage with fork shaft system (multi-function), pintype and hook-type versions

## FORKS AND FORK SHAFT SYSTEMS (fss)



Different cross-sections, lengths, tapering, and reinforcements



Fork shaft system hook-type



Fork shaft system, pin-type

## ATTACHMENTS



Different container spreaders with inverted forks and fork shafts



Multiple paper roll clamp (single or double)

## COIL RAMS



Single coil ram with fork shaft



Double coil ram with fork shaft



Single coil ram, integral version



Fork rotator carriage



Concrete tube clamp (different versions)

### ALSO AVAILABLE

- Fork extensions: pantograph, lifting hook, lifting jib
- Pipe and tube clamp
- Pallet handlers: double, triple
- Magnets for lifting steel

And more available upon request

10 TO 65 TONS

# The world's hardest-working forklifts

When you buy a Konecranes forklift, you are investing in time-tested technology with innovative, eco-efficient features to enhance productivity and cut lifecycle costs. We offer a range of solutions and technologies to reduce engine, drive train and tire wear,

extend the functional life of your forklift and decrease your running expenses. When your lifting needs change, a well-maintained forklift also has high resale value.



## 10 TO 18 TONS



MODEL NAME	CAPACITY	WHEELBASE
SMV 10-600 CS	10 tons at 600 mm	2800 mm
SMV 12-600 CS	12 tons at 600 mm	3000 mm
SMV 10-600 C	10 tons at 600 mm	3000 mm
SMV 12-600 C	12 tons at 600 mm	3000 mm

MODEL NAME	CAPACITY	WHEELBASE
SMV 10-1200 C	10 tons at 1200 mm	3250 mm
SMV 13.6-600 C	13.6 tons at 600 mm	3250 mm

MODEL NAME	CAPACITY	WHEELBASE
SMV 12-1200 C	12 tons at 1200 mm	3500 mm
SMV 16-600 C	16 tons at 600 mm	3500 mm
SMV 16-900 C	16 tons at 900 mm	3500 mm

MODEL NAME	CAPACITY	WHEELBASE
SMV 15-1200 C	15 tons at 1200 mm	3750 mm
SMV 16-1200 C	16 tons at 1200 mm	3750 mm
SMV 18-600 C	18 tons at 600 mm	3750 mm
SMV 18-900 C	18 tons at 900 mm	3750 mm

## 37 TO 65 TONS



MODEL NAME	CAPACITY	WHEELBASE
SMV 37-1200 C	37 tons at 1200 mm	5000 mm

MODEL NAME	CAPACITY	WHEELBASE
SMV 52-1200 C	52 tons at 1200 mm	6000 mm
SMV 55-1200 C	55 tons at 1200 mm	6000 mm

MODEL NAME	CAPACITY	WHEELBASE
SMV 42-1200 C	42 tons at 1200 mm	5500 mm
SMV 45-1200 C	45 tons at 1200 mm	5500 mm
SMV 50-1200 C	50 tons at 1200 mm	6000 mm

MODEL NAME	CAPACITY	WHEELBASE
SMV 60-1500 C	60 tons at 1500 mm	6000 mm
SMV 65-1200 C	65 tons at 1200 mm	6000 mm

## 18 TO 33 TONS



MODEL NAME	CAPACITY	WHEELBASE
SMV 18-1200 C	18 tons at 1200 mm	4000 mm
SMV 20-1200 C	20 tons at 1200 mm	4000 mm

MODEL NAME	CAPACITY	WHEELBASE
SMV 28-1200 C	28 tons at 1200 mm	4500 mm
SMV 32-1200 C	32 tons at 1200 mm	4750 mm
SMV 33-1200 C	33 tons at 1200 mm	4750 mm

MODEL NAME	CAPACITY	WHEELBASE
SMV 22-1200 C	22 tons at 1200 mm	4250 mm
SMV 23.6-1200 C	23.6 tons at 1200 mm	4250 mm
SMV 25-1200 C	25 tons at 1200 mm	4250 mm

MODEL NAME	CAPACITY	WHEELBASE
SMV 28-1200 B RoRo	28 tons at 1200 mm	4500 mm
SMV 32-1200 B RoRo	32 tons at 1200 mm	4750 mm

Other models upon request

## E-VER 10 TO 18 TONS



MODEL NAME	CAPACITY	WHEELBASE
E-VER 10-600 C	10 tons at 600 mm	3000 mm
E-VER 12-600 C	12 tons at 600 mm	3000 mm

MODEL NAME	CAPACITY	WHEELBASE
E-VER 10-1200 C	10 tons at 1200 mm	3250 mm
E-VER 13.6-600 C	13.6 tons at 600 mm	3250 mm

MODEL NAME	CAPACITY	WHEELBASE
E-VER 12-1200 C	12 tons at 1200 mm	3500 mm
E-VER 16-600 C	16 tons at 600 mm	3500 mm
E-VER 16-900 C	16 tons at 900 mm	3500 mm

MODEL NAME	CAPACITY	WHEELBASE
E-VER 15-1200 C	15 tons at 1200 mm	3750 mm
E-VER 16-1200 C	16 tons at 1200 mm	3750 mm
E-VER 17-1200 C	17 tons at 1200 mm	3750 mm
E-VER 18-600 C	18 tons at 600 mm	3750 mm
E-VER 18-900 C	18 tons at 900 mm	3750 mm

## TECHNICAL DATA : SMV 55-1200C

Machine type		SMV 55-1200C
<b>LOAD HANDLING DATA</b>		
Lifting capacity / Load center	kg / mm	55 000 / 1200
Maximum lifting speed, unloaded / at 70% of rated load	m/s	0,24 / 0,22
Maximum lowering speed, unloaded / at rated load	m/s	0,38 / 0,40
<b>DRIVING DATA</b>		
Drive speed forward, unloaded / at rated load	km/h	26 / 22
Drive speed reverse, unloaded / at rated load	km/h	18 / 17
Incline (driving ability) at rated load at 0 km/h / at 2 km/h	%	30 / 20
Towing (power ability) at rated load at 0 km/h / at 2 km/h	kN	350 / 243
<b>SERVICE WEIGHT / AXLE LOADS</b>		
Service weight	kg	63 500
Axle load front, unloaded / at rated load	kg	32 000 / 111 100
Axle load rear, unloaded / at rated load	kg	31 500 / 7 400
<b>ENGINE</b>		
Engine make, model name		Cummins X12-C350
Emission approval EU / US		Stage V / Tier 4 Final
Monitoring / emission controlled / CanBus		Yes / yes / yes
Fuel / type of engine		Diesel / 4-stroke CI
Rated power ISO 3046 / max speed	kW / rpm	283 / 2000
Rated torque ISO 3046 / at speed	Nm / rpm	1857 / 1400
Displacement / No. of cylinders / configuration	L / /	11,8 / 6 / Inline
Fuel consumption, normal operations	L/h	15-18
Alternator, type / power / amperage	W / Amp	AC / 3 080 / 110
Starting battery, voltage / capacity	V / Ah	2 x 12 / 140
<b>TRANSMISSION</b>		
Transmission make, model name		DANA TE-30
Monitoring / reverse protection / CanBus		Yes / yes / yes
Clutch, type		Torque converter
Transmission type / type of shift gear		Softshift – Powershift / Automatic
No. of gears, forward/reverse		5/3
<b>DRIVE AXLE &amp; STEER SYSTEM</b>		
Drive axle make, model name		Kessler D106
Drive axle type		Differential + hub reduction
Service brake, type / affected wheels		Oil cooled Wet Disc Brakes / drive wheels
Parking brake, type / affected wheels		Dry disc brake / spring applied / drive wheels
<b>STEER AXLE &amp; STEER SYSTEM</b>		
Steer axle make / type		Konecranes / double acting single cylinder
Steering system		Hydraulic servo assisted / power steering
<b>WHEELS</b>		
Number of wheels, front+rear / Type (*driven)		4*+2 / pneumatic
Tire pressure front / rear	MPa	1,0 / 1,0
Tire dimensions (Ply rating) front / rear	Inch (No)	18.00 x 33" (PR 40) / 18.00 x 33" (PR 40)
Rim dimension front / rear	Inch	13.00 x 33" / 13.00 x 33"
<b>HYDRAULIC SYSTEM</b>		
Hydraulic pump make, model name		Parker P2-series
Hydraulic system / pump type		Load sensing system / variable axial piston pump
Power-on-demand / Low energy		Yes / yes
Hydraulic oil pressure mast	MPa	24
<b>TANK VOLUMES</b>		
Fuel tank volume	L	550
Hydraulic tank volume	L	630
<b>LIFTING EQUIPMENT</b>		
Lift mast model / mast type / design		Konecranes duplex standard / 2-stage / free visibility
Carriage make / model		Konecranes / Hydraulic integral roller type
Fork make / model		Konecranes / roller type
<b>OTHERS</b>		
Noise level (inside Cab / Lm) DIN 45635	dB(A)	68
Noise level (inside Cab/ LpAZ) EN 12053 (EU + EFTA only)	dB(A)	73
Maximum noise level (outside Lwa) 2000/14/EC (EU + EFTA only)	LWA	109
<b>NORMS &amp; STANDARDS</b>		
Stability of Industrial Trucks ISO 22915-2		Yes
Safety of Industrial Trucks EN ISO 3691-1		Yes

KONECRANES LIFTRUCKS AB

Box 103, SE-28523 Markaryd, SWEDEN

Data in this document is based on a standard machine, impact from modifications or customizations are not covered.

Konecranes Liftrucks reserve the right to alter design and specification without prior notice

## TECHNICAL DATA : SMV 55-1200C

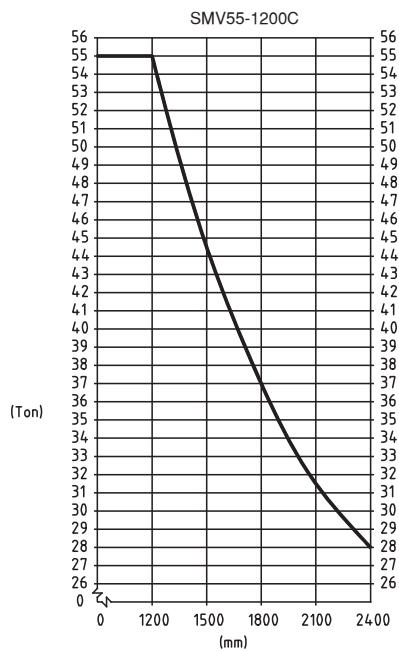
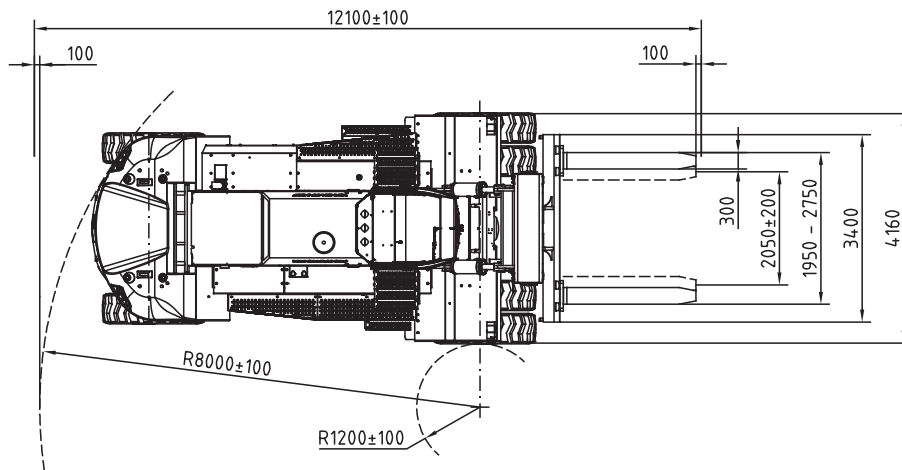
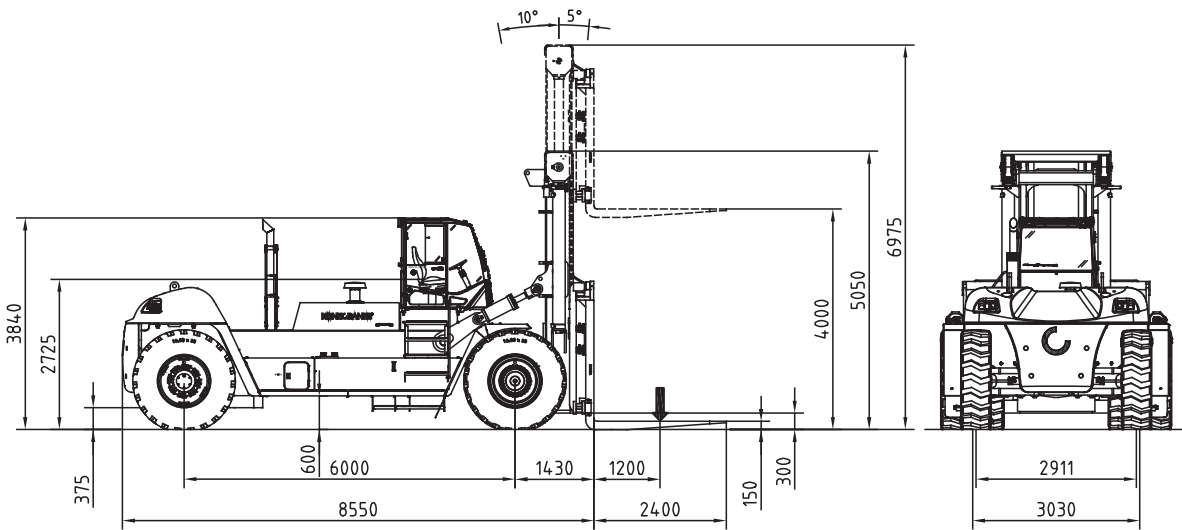

**Konecranes is a world-leading group of Lifting Businesses™, serving a broad range of customers, including manufacturing and process industries, shipyards, ports and terminals. Konecranes provides productivity enhancing lifting solutions as well as services for lifting equipment of all makes. In 2019, Group sales totaled EUR 3.33 billion. Including MHE-Demag, the Group has around 17,000 employees in 50 countries. Konecranes shares are listed on the Nasdaq Helsinki (symbol: KCR).**

© 2023 Konecranes. All rights reserved. 'Konecranes', 'Lifting Businesses' and  are either registered trademarks or trademarks of Konecranes.

This publication is for general informational purposes only. Konecranes reserves the right at any time, without notice, to alter or discontinue the products and/or specifications referenced herein. This publication creates no warranty on the part of Konecranes, express or implied, including but not limited to any implied warranty or merchantability or fitness for a particular purpose.



Hornweg 18  
1045 AR Amsterdam  
The Netherlands

+31 20 497 4101  
[www.forkliftcenter.com](http://www.forkliftcenter.com)

