

20ft Container Spreader

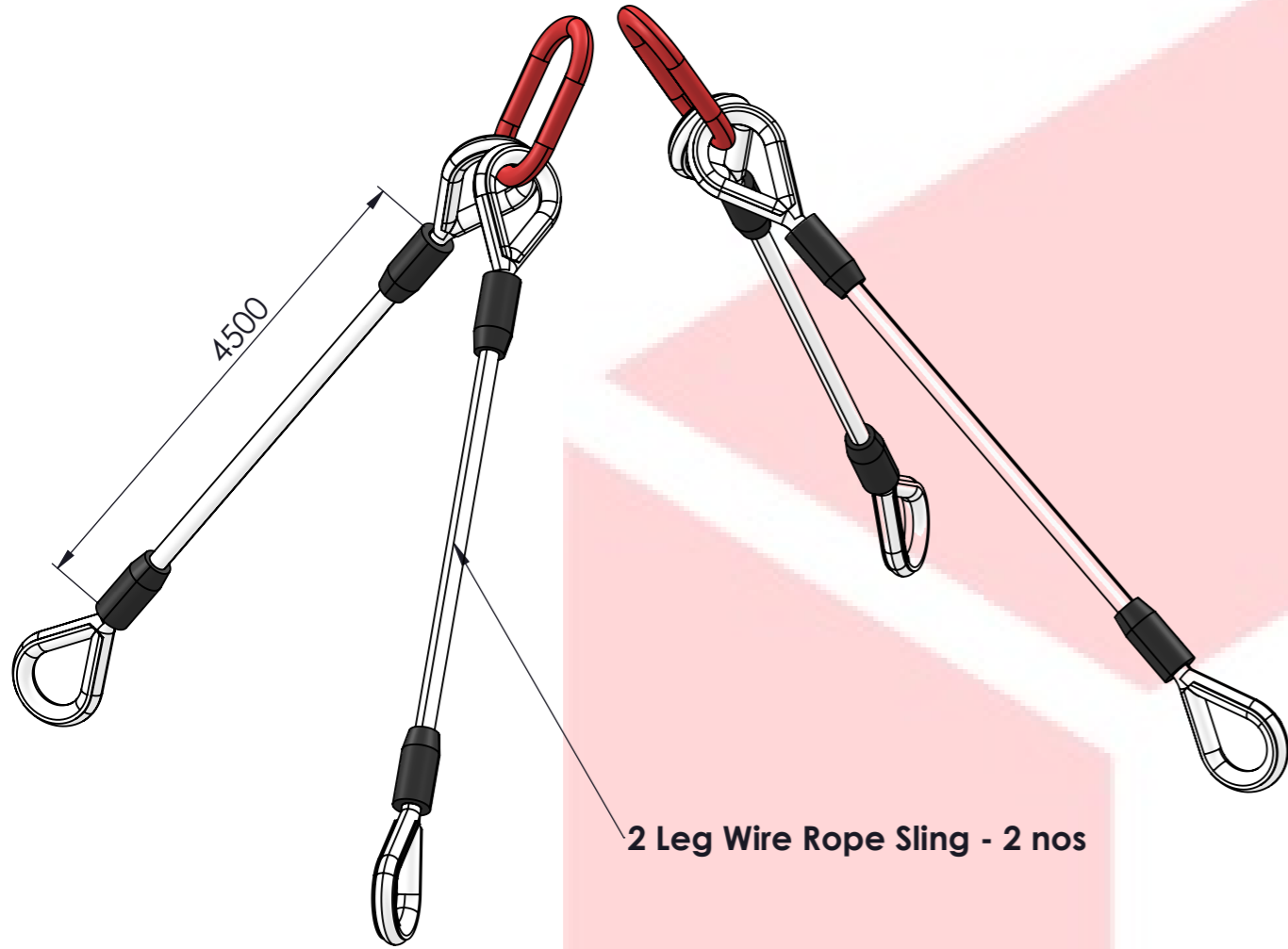

Spring for Center Part Rotation

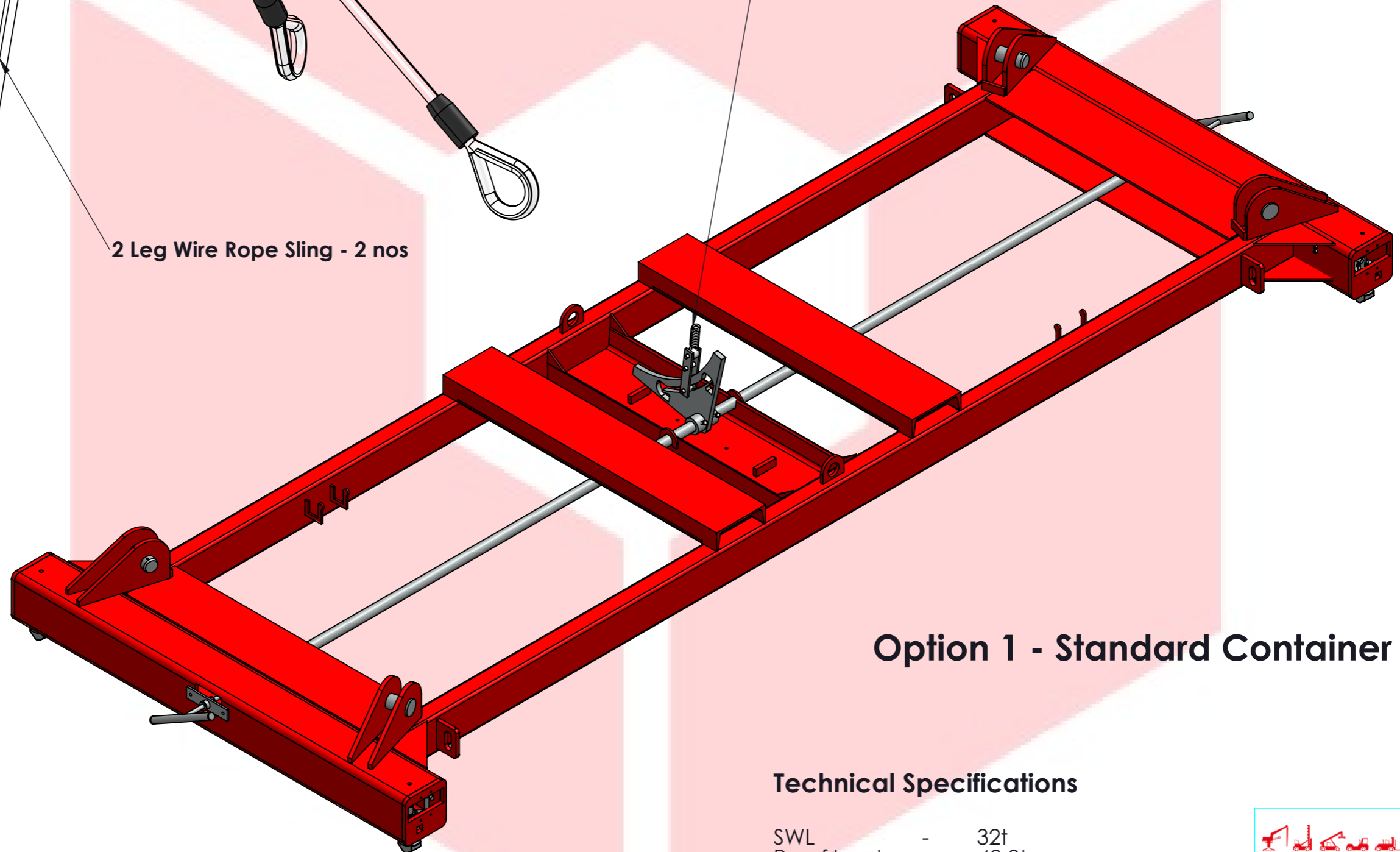

Option 1 - Standard Container Spreader

Technical Specifications

SWL	-	32t
Proof load	-	42.8t
Self weight	-	1.8t
Paint	-	RAL 3020 (RED)
Slings Type	-	2 x 2 Leg Wire Rope Sling

				32 T Container Spreader 20 Ft	
REVISIONS		DRAWN: Amandeep		DATE: 10-10-2024	
NO.	DATE	SUBJECT	APD	ORDER:	PRINCIPAL:
				SCALE: 1:50	CADNAME: EP106_20FX32
				CHECKED:	REV: 4
				PAGE 1 OF 6 PAGES	FORM: A3
DO NOT MEASURE ON THE DRAWING - ALL DIMENSIONS ARE IN MM This drawing can not be copied or given to other persons without written agreement. The drawing remains property of the company PRONK.					

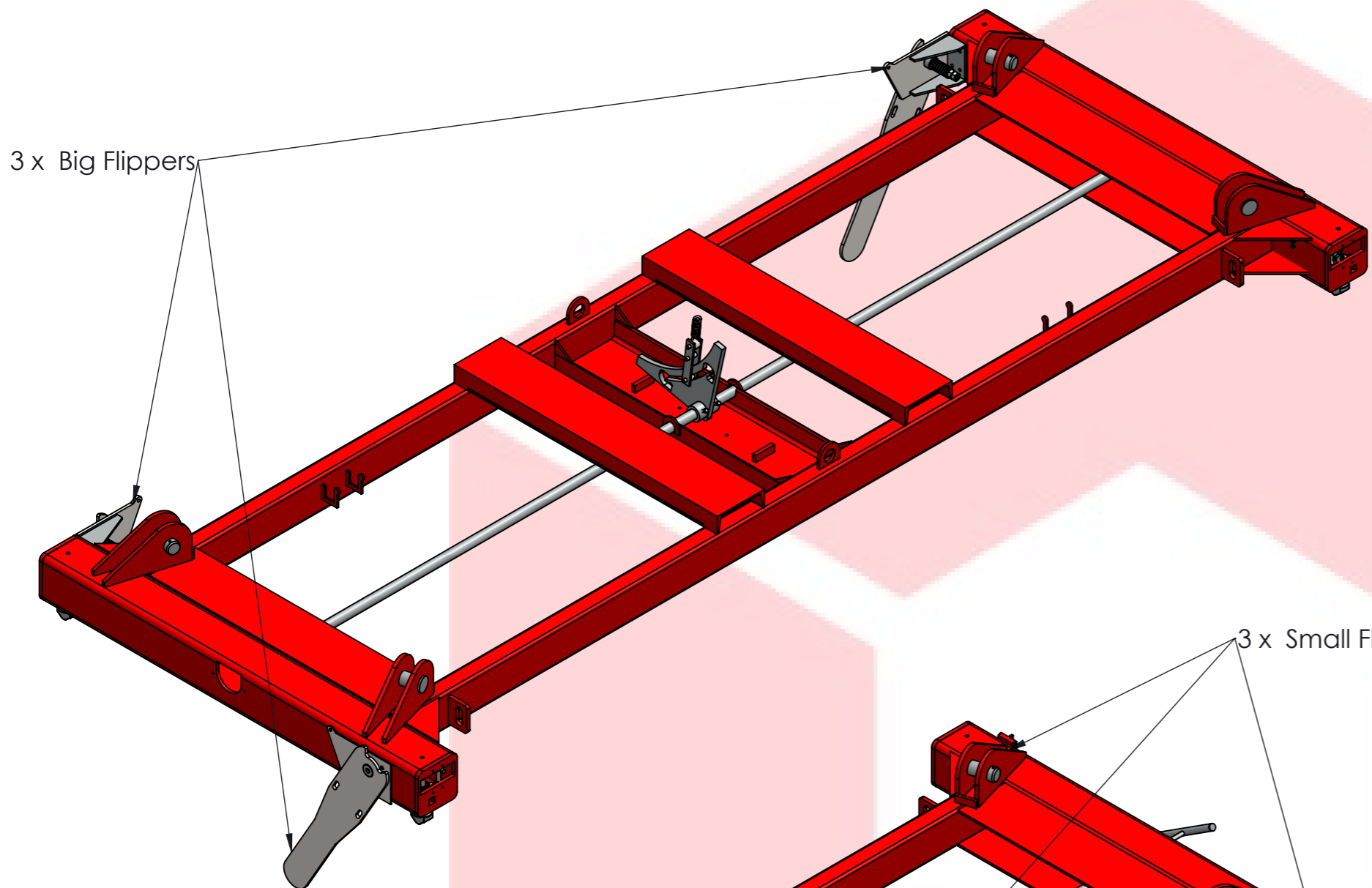

3 x Big Flippers

Handle will be removed while using big flippers

Option 2 - With Big Flippers

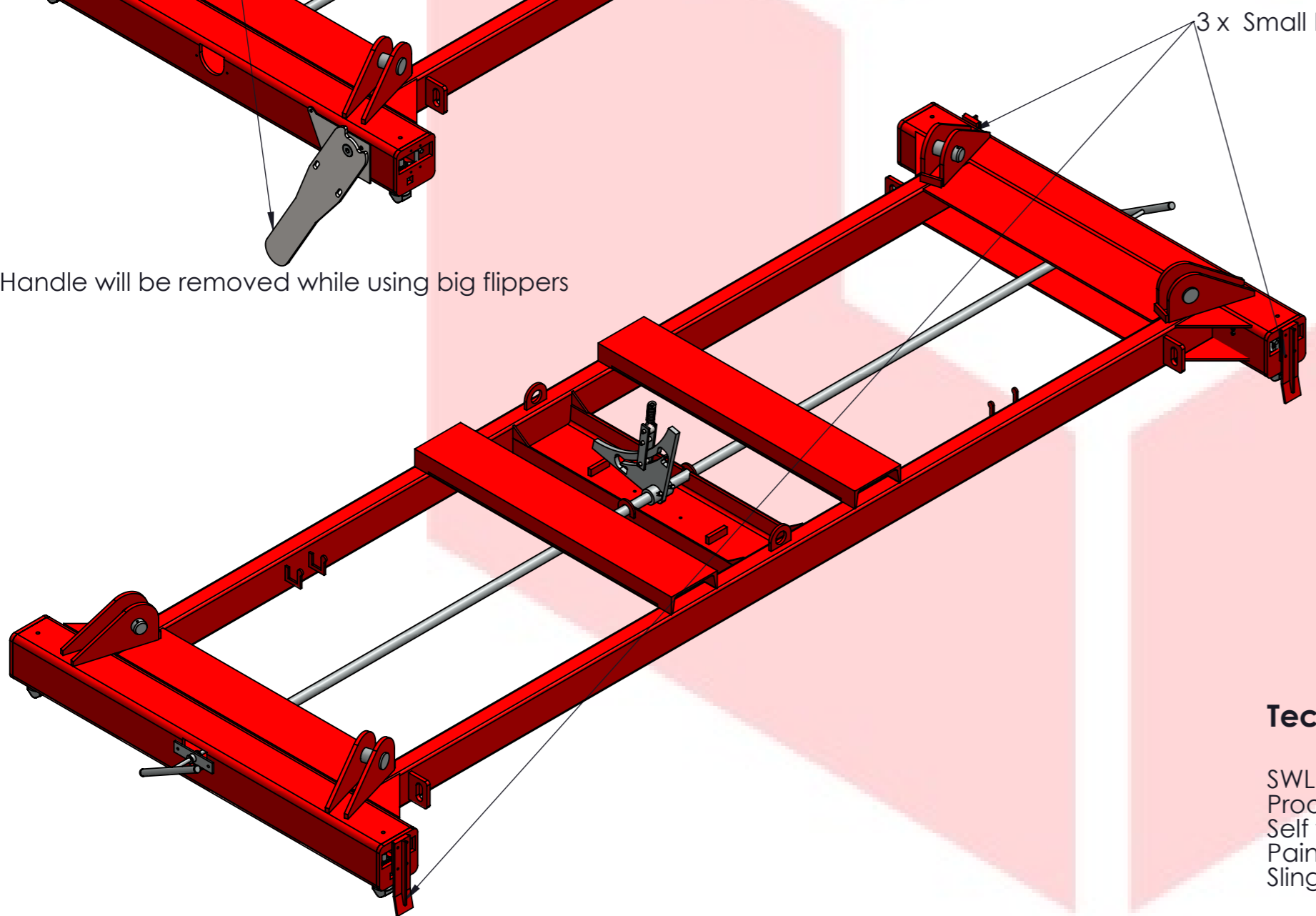

3 x Small Flippers

Option 3 - With Small Flippers

Technical Specifications

- SWL - 32t
- Proof load - 42.8t
- Self weight - 1.8t
- Paint - RAL 3020 (RED)
- Slings Type - 2 x 2 Leg Wire Rope Slings

32 T Container Spreader
20 Ft

REVISIONS				DRAWN: Amandeep		DATE: 10-10-2024	
NO.	DATE	SUBJECT	APD	SCALE:	ORDER:	PRINCIPAL:	
				1:50			
				CHECKED:	CADNAME: EP106_20FX32	REV: 4	
					PAGE 2 OF 6 PAGES	FORM: A3	

DO NOT MEASURE ON THE DRAWING - ALL DIMENSIONS ARE IN MM
This drawing can not be copied or given to other persons without written agreement. The drawing remains property of the company PRONK.

Overall Length : 6081

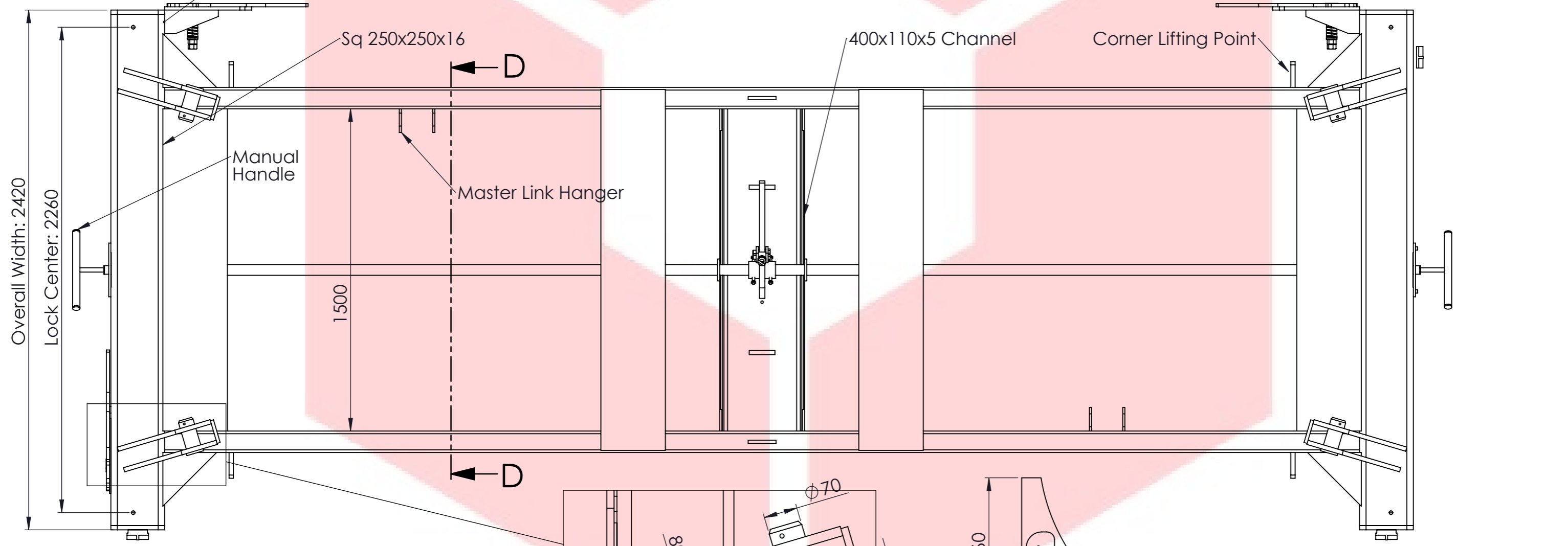
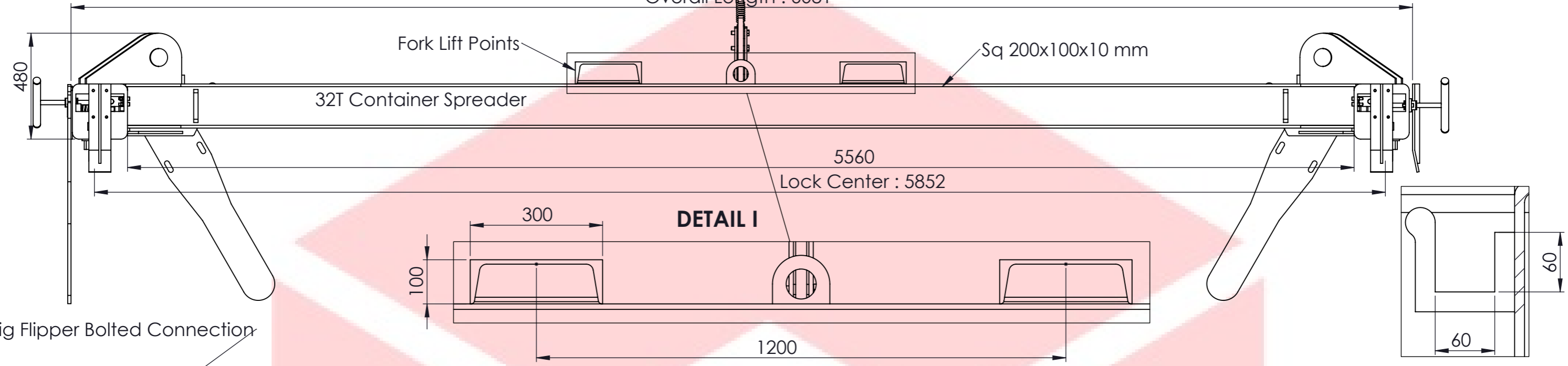

32 T Container Spreader
20 Ft

REVISIONS				DRAWN: Amandeep		DATE: 10-10-2024	
NO	DATE	SUBJECT	APD	ORDER:	PRINCIPAL:	CADNAME: EP106_20FX32	REV: 4
				1:50			
				CHECKED:			
						PAGE 3 OF 6 PAGES	FORM: A3

DO NOT MEASURE ON THE DRAWING - ALL DIMENSIONS ARE IN MM
This drawing can not be copied or given to other persons without written agreement. The drawing remains property of the company PRONK.

Spreader Width : 2420
 20ft Container Width : 2438

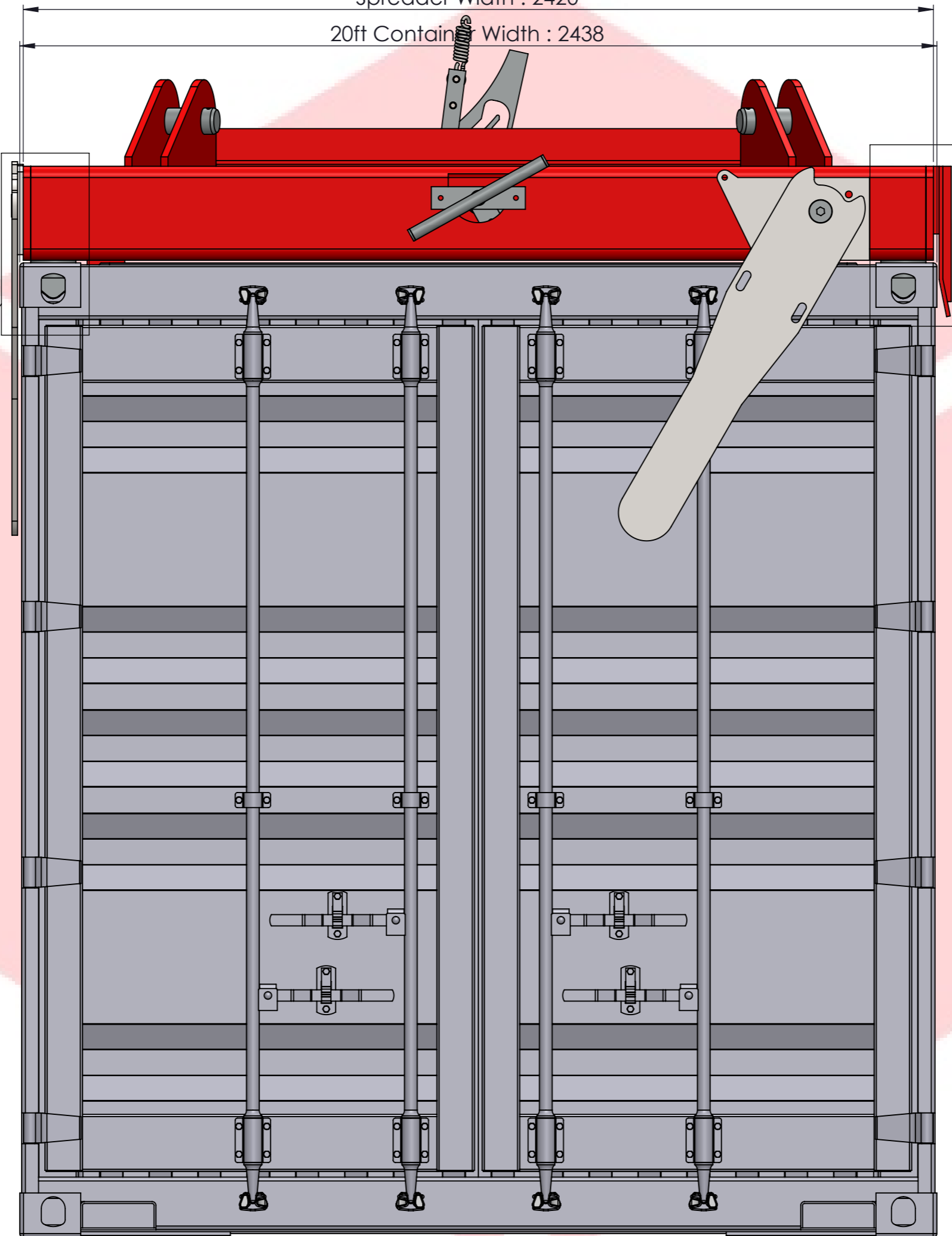

SIDE VIEW

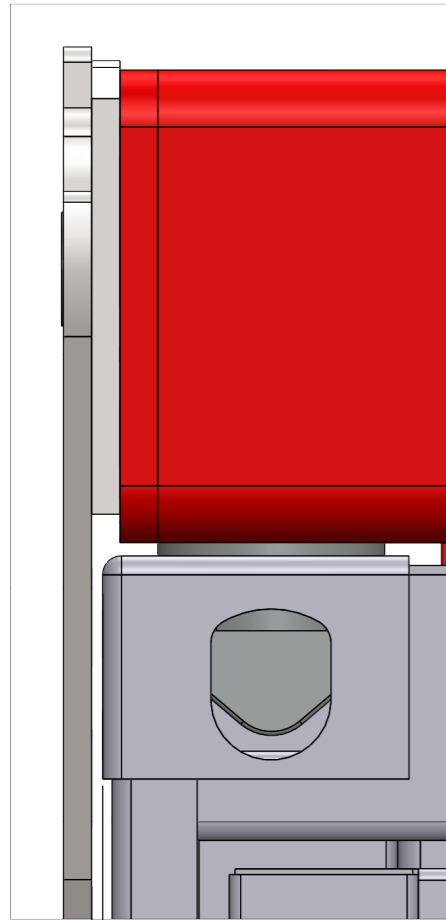

6

DETAIL L
 SCALE 1 : 4

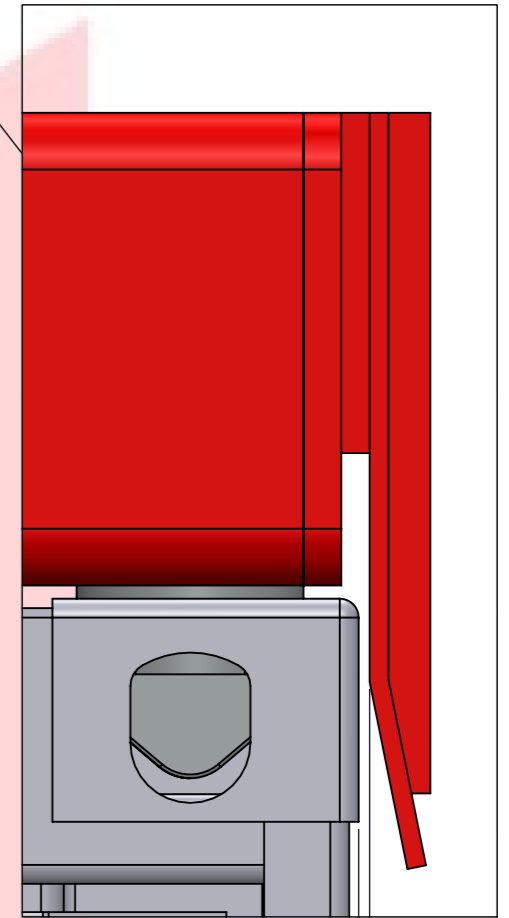

6

DETAIL K
 SCALE 1 : 4

32 T Container Spreader
 20 Ft

				DRAWN: Amandeep SCALE: 1:50 CHECKED:		DATE: 10-10-2024 ORDER: PRINCIPAL: CADNAME: EP106_20FX32 PAGE 4 OF 6 PAGES FORM: A3	
REVISIONS	NO	DATE	SUBJECT	APVD	REV: 4		

DO NOT MEASURE ON THE DRAWING - ALL DIMENSIONS ARE IN MM
 This drawing can not be copied or given to other persons without written agreement. The drawing remains property of the company PRONK.

Spreader Beam Length :6066

20ft Container Length :6058

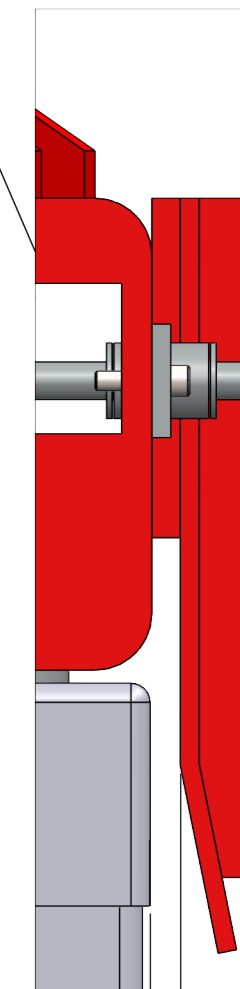
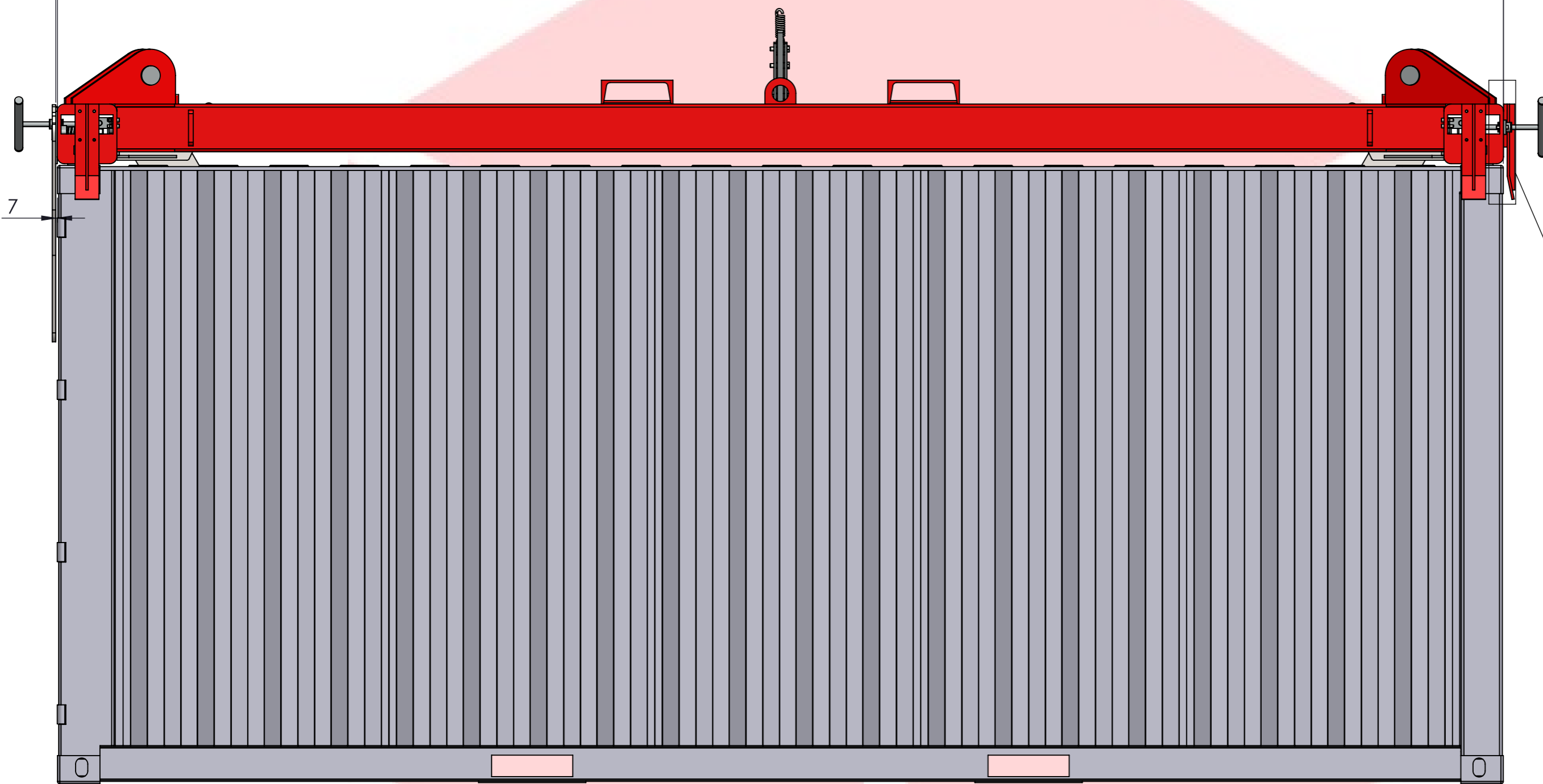

16

FRONT VIEW

DETAIL ○

SCALE 1 : 4



32 T Container Spreader
20 Ft

REVISIONS				DRAWN:	DATE:
NO	DATE	SUBJECT	APD	Amandeep	10-10-2024
				ORDER:	
				SCALE:	PRINCIPAL:
				1:50	CADNAME: EP106_20FX32 REV: 4
				CHECKED:	PAGE 5 OF 6 PAGES FORM: A3

DO NOT MEASURE ON THE DRAWING - ALL DIMENSIONS ARE IN MM
This drawing can not be copied or given to other persons without written agreement. The drawing remains property of the company PRONK.

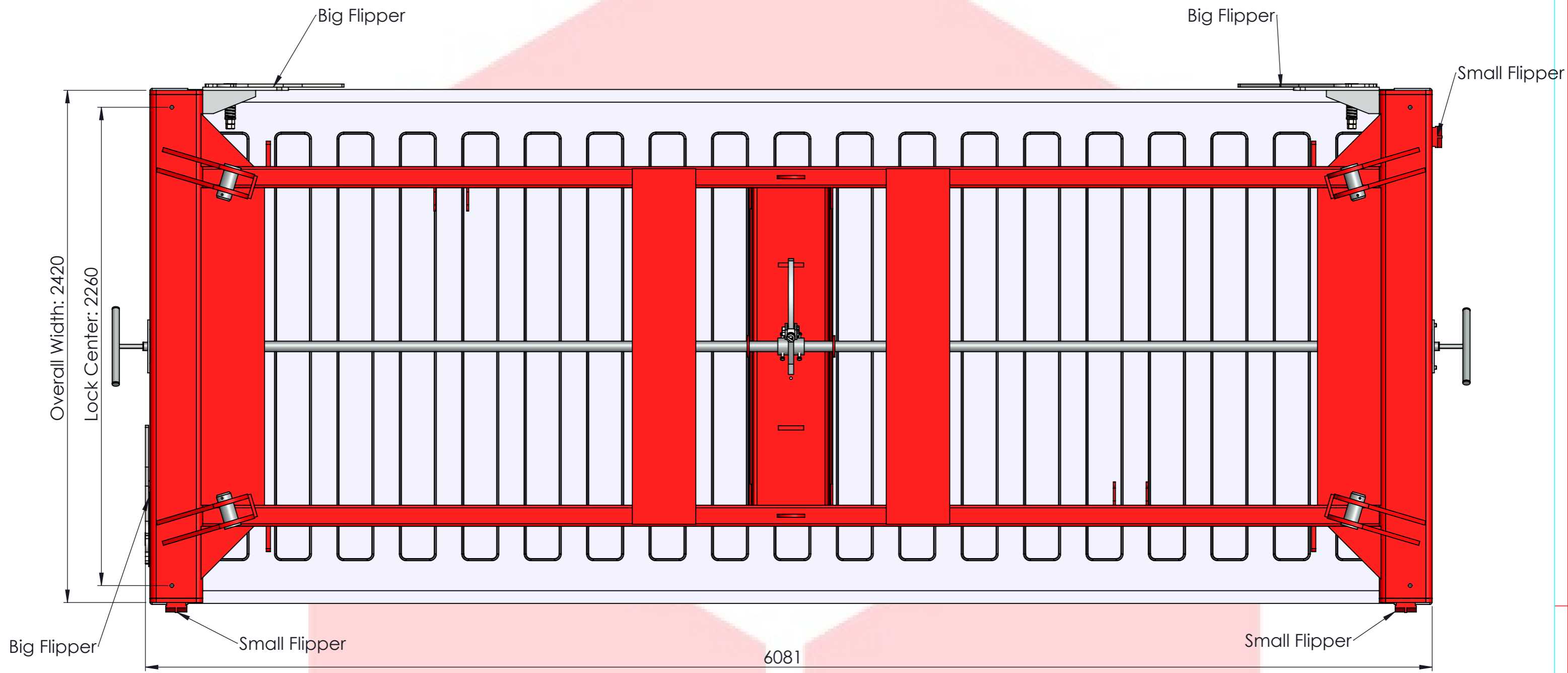

TOP VIEW

32 T Container Spreader
20 Ft

REVISIONS				DRAWN:	DATE:
NO.	DATE	SUBJECT	APD	Amandeep	10-10-2024
				SCALE:	ORDER:
				1:50	PRINCIPAL:
				CHECKED:	CADNAME: EP106_20FX32 REV: 4
					PAGE 6 OF 6 PAGES FORM: A3

DO NOT MEASURE ON THE DRAWING - ALL DIMENSIONS ARE IN MM
This drawing can not be copied or given to other persons without written agreement. The drawing remains property of the company PRONK.