

# 20ft Container Spreader

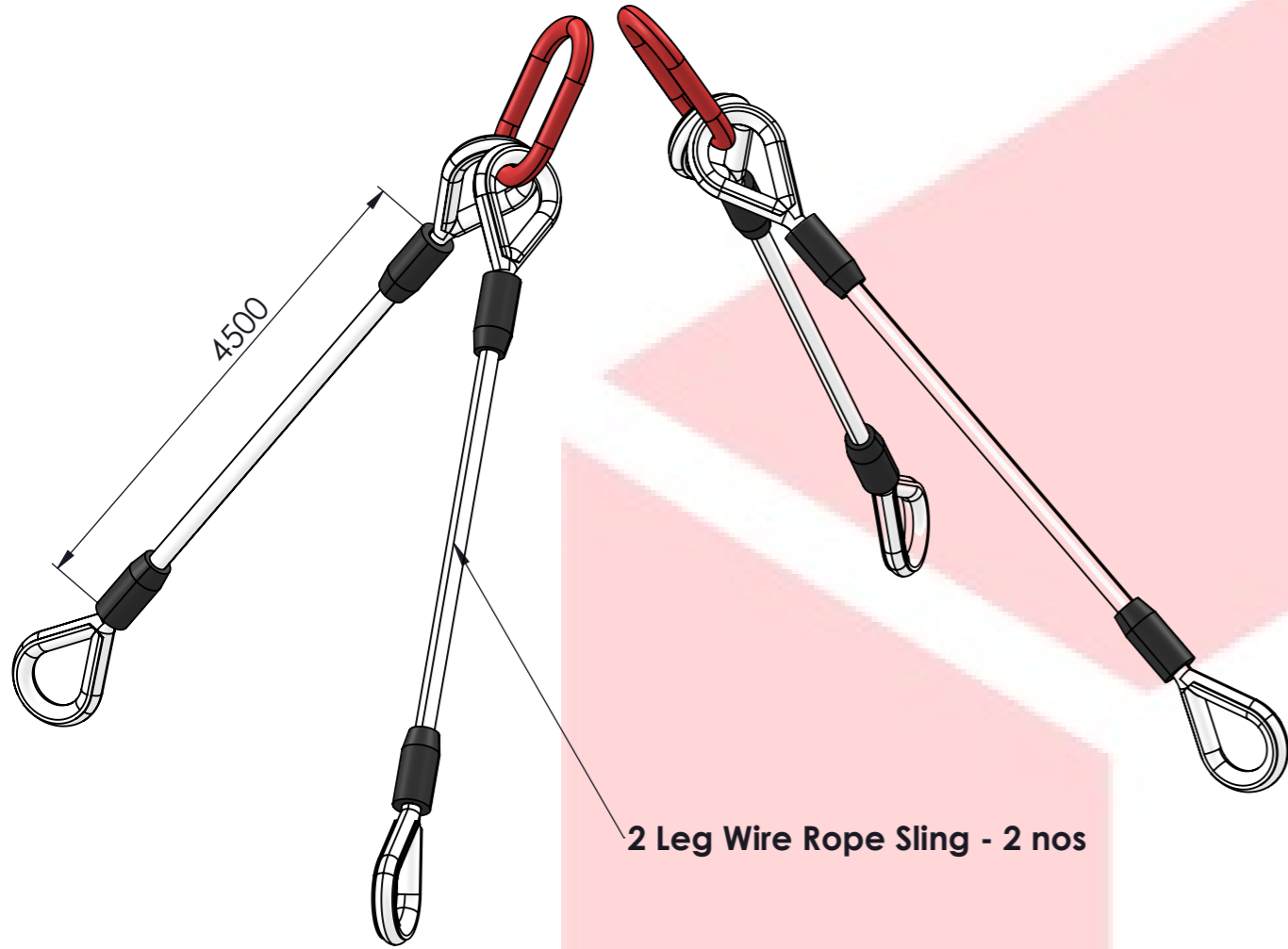

2 Leg Wire Rope Sling - 2 nos

Spring for Center Part Rotation

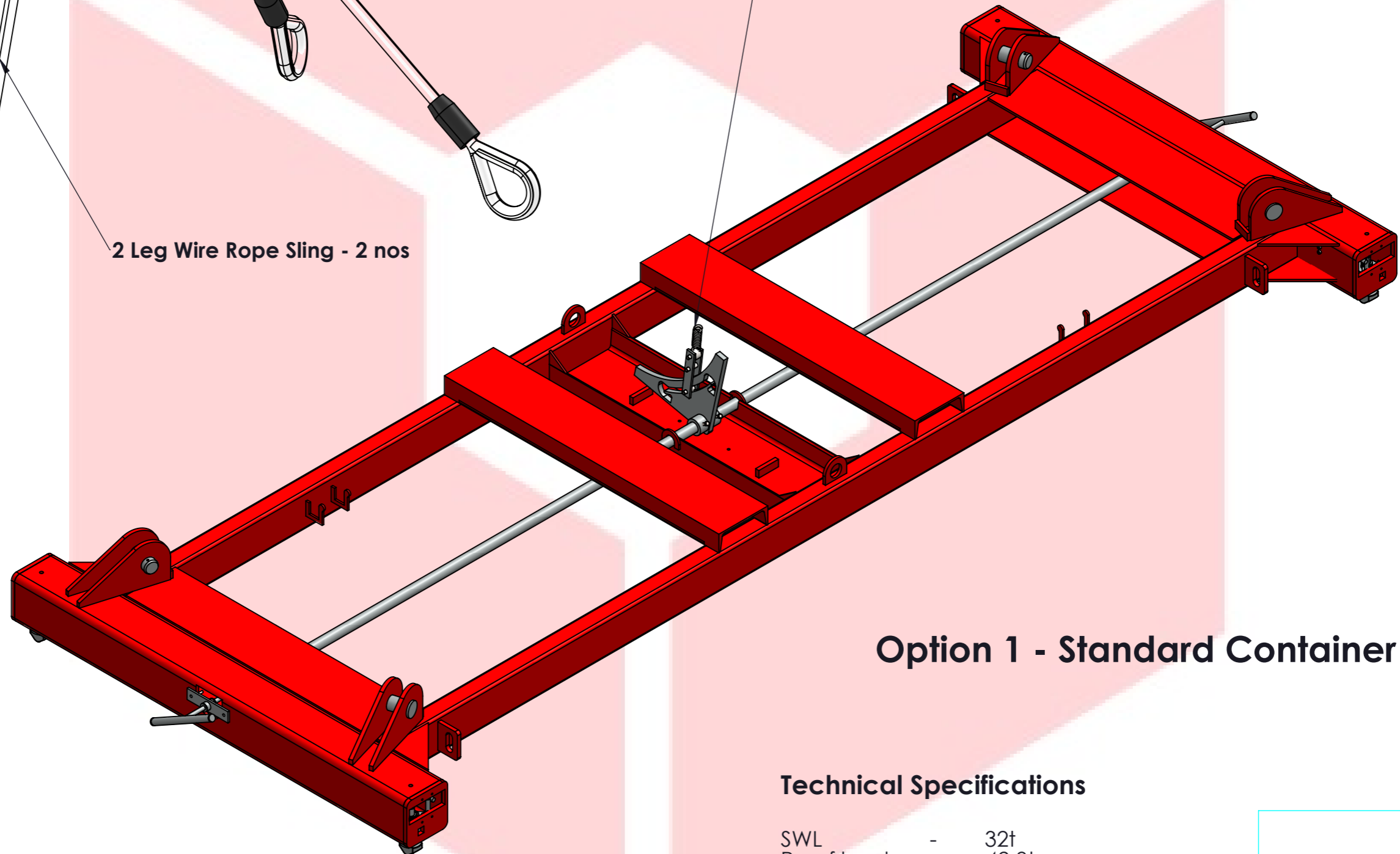

## Option 1 - Standard Container Spreader

### Technical Specifications

SWL	-	32t
Proof load	-	42.8t
Self weight	-	1.8t
Paint	-	RAL 3020 (RED)
Slings Type	-	2 x 2 Leg Wire Rope Sling

REVISIONS				32 T Container Spreader 20 Ft	
NO	DATE	SUBJECT	APD	DRAWN:	DATE: 27-09-2024
				Amandeep	ORDER:
				SCALE:	PRINCIPAL:
				1:50	CADNAME: EP106_20FIX32
				CHECKED:	REV: 3
					PAGE 1 OF 7 PAGES
					FORM: A3

DO NOT MEASURE ON THE DRAWING - ALL DIMENSIONS ARE IN MM  
This drawing can not be copied or given to other persons without written agreement. The drawing remains property of the company PRONK.

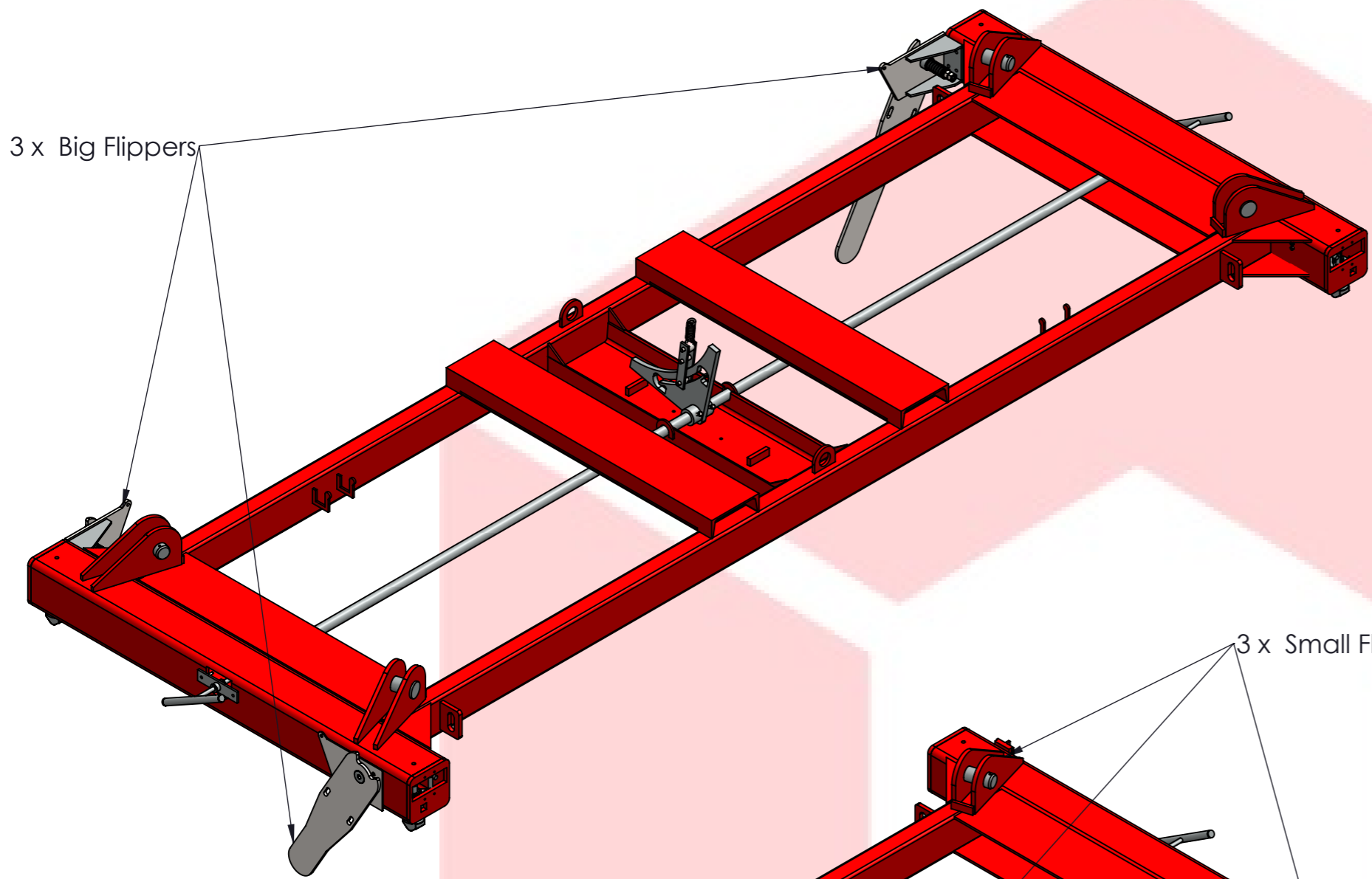

**Option 2 - With Big Flippers**

**Note : 1 Big Flipper length is reduced 180mm because it was colliding with the handle**

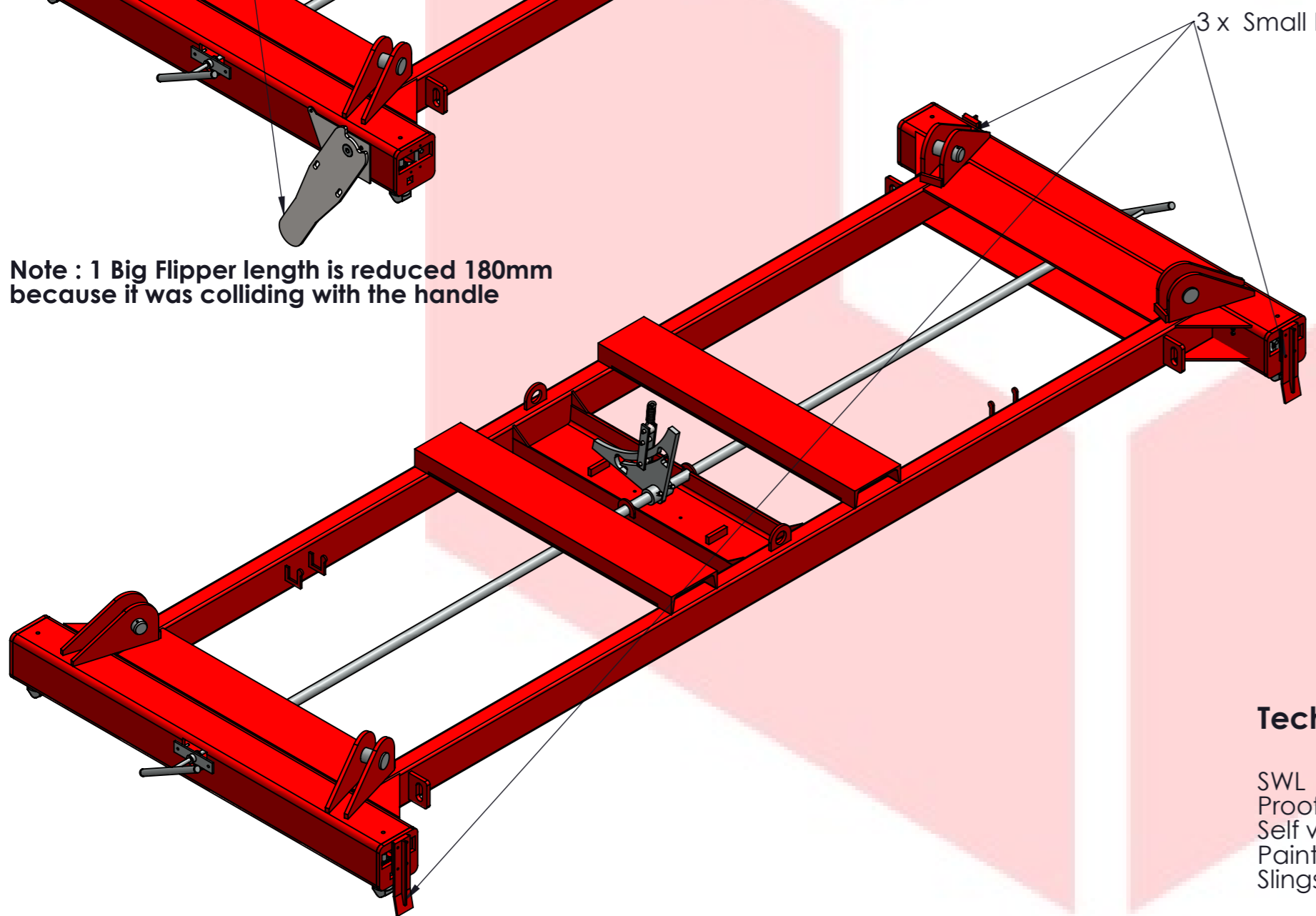

**Option 3 - With Small Flippers**

**Technical Specifications**

- SWL - 32t
- Proof load - 42.8t
- Self weight - 1.8t
- Paint - RAL 3020 (RED)
- Slings Type - 2 x 2 Leg Wire Rope Sling

				32 T Container Spreader 20 Ft	
REVISIONS				DRAWN: Amandeep	DATE: 27-09-2024
NO	DATE	SUBJECT	APD	ORDER:	PRINCIPAL:
				SCALE: 1:50	CADNAME: EP106_20FIX32
				CHECKED:	REV: 3
				PAGE 2 OF 7 PAGES	FORM: A3
DO NOT MEASURE ON THE DRAWING - ALL DIMENSIONS ARE IN MM This drawing can not be copied or given to other persons without written agreement. The drawing remains property of the company PRONK.					



Spreader Width : 2420  
 20ft Container Width : 2438

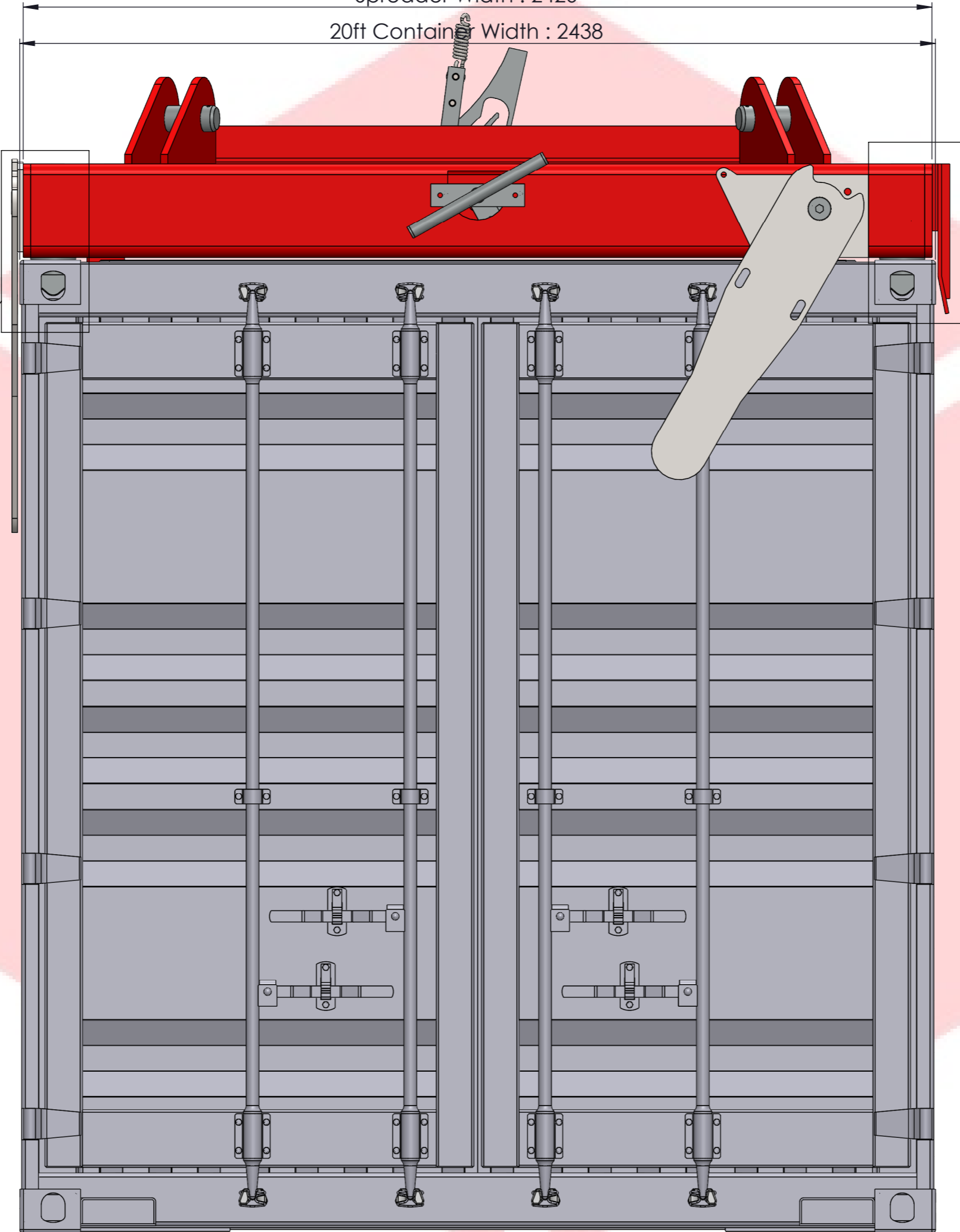

**SIDE VIEW**

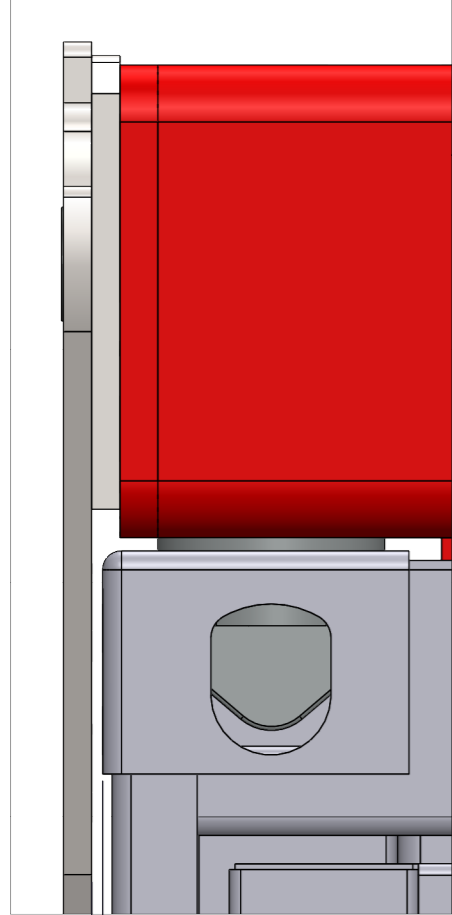

6

**DETAIL L**  
 SCALE 1 : 4

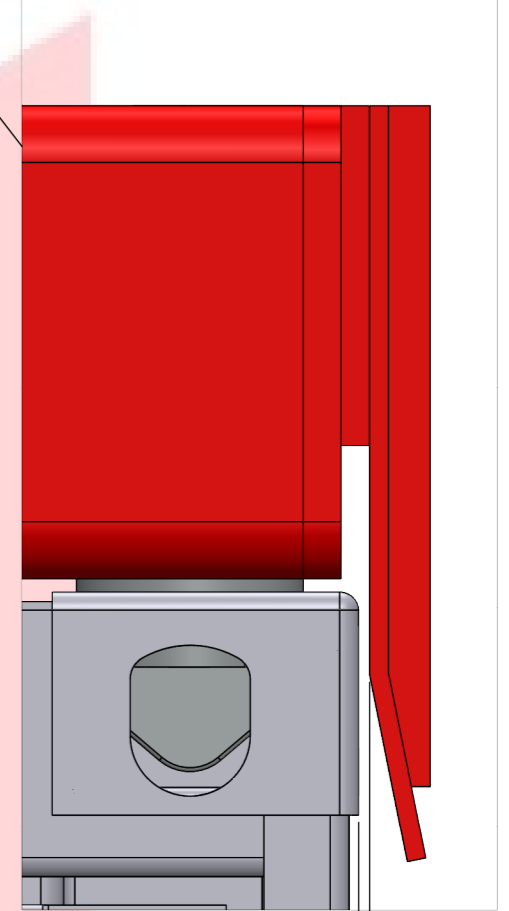

6

**DETAIL K**  
 SCALE 1 : 4

REVISIONS				DRAWN: Amandeep		DATE: 27-09-2024	
NO	DATE	SUBJECT	APD	SCALE:	ORDER:	PRINCIPAL:	
				1:50			
				CHECKED:	CADNAME: EP106_20FX32	REV: 3	
					PAGE 4 OF 7 PAGES	FORM: A3	

DO NOT MEASURE ON THE DRAWING - ALL DIMENSIONS ARE IN MM  
 This drawing can not be copied or given to other persons without written agreement. The drawing remains property of the company PRONK.

32 T Container Spreader  
 20 Ft

Spreader Beam Length :6066

20ft Container Length :6058

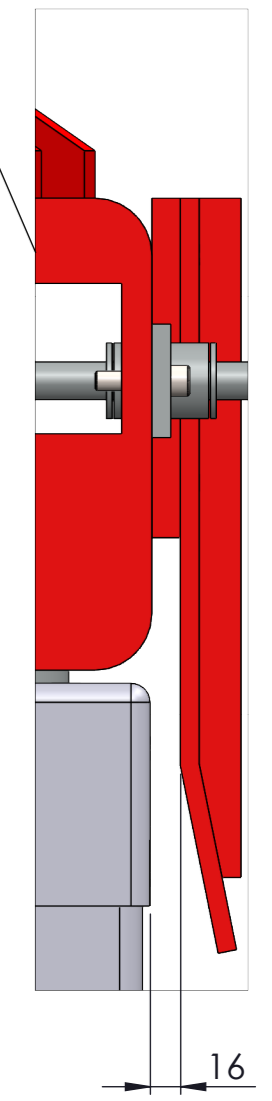
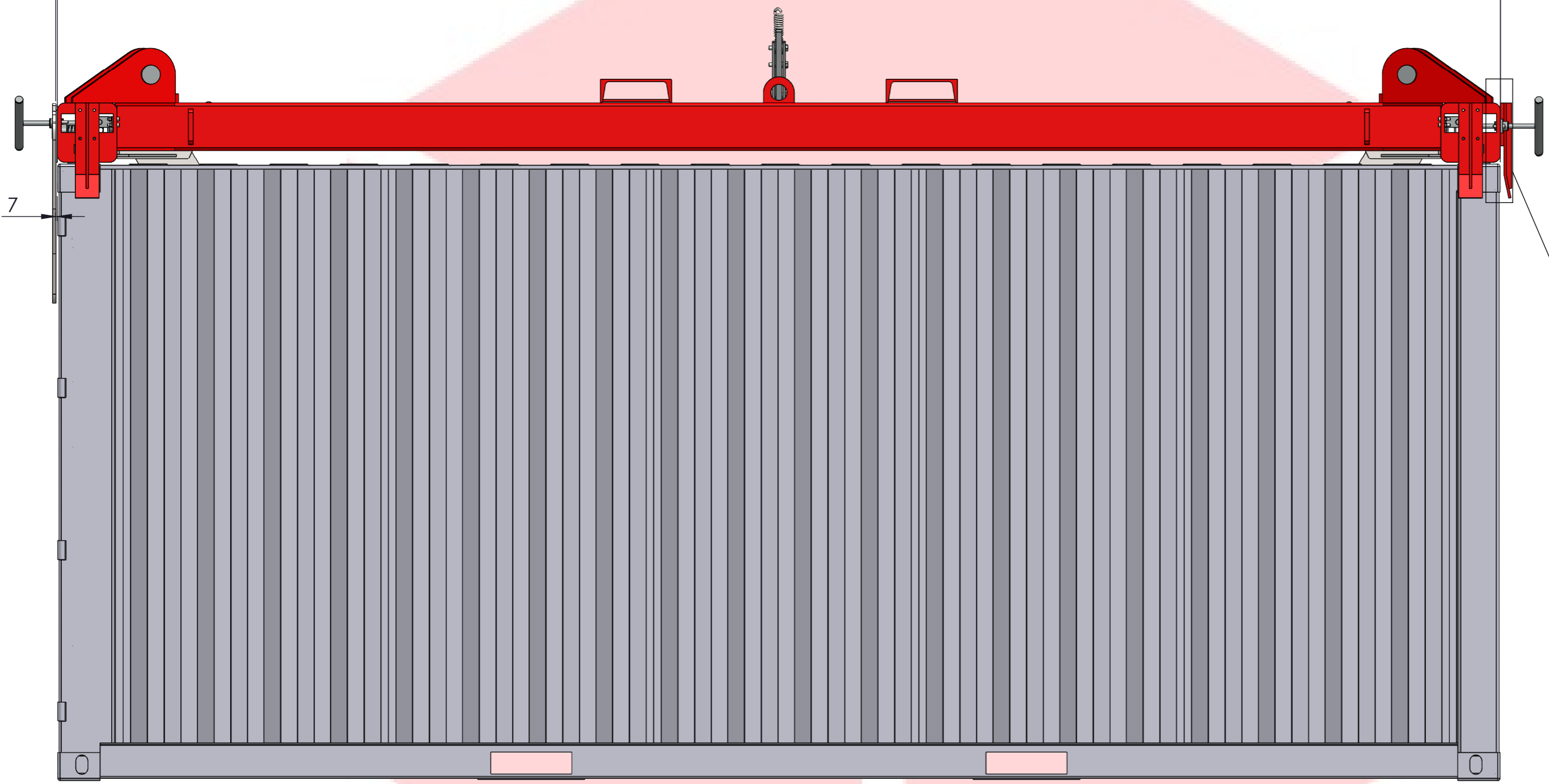

**FRONT VIEW**

**DETAIL ○**  
SCALE 1 : 4

32 T Container Spreader  
20 Ft

REVISIONS				DRAWN:	DATE:
NO	DATE	SUBJECT	APD	Amandeep	27-09-2024
				ORDER:	
				SCALE:	PRINCIPAL:
				1:50	CADNAME: EP106_20FX32 REV: 3
				CHECKED:	PAGE 5 OF 7 PAGES FORM: A3

DO NOT MEASURE ON THE DRAWING - ALL DIMENSIONS ARE IN MM  
This drawing can not be copied or given to other persons without written agreement. The drawing remains property of the company PRONK.

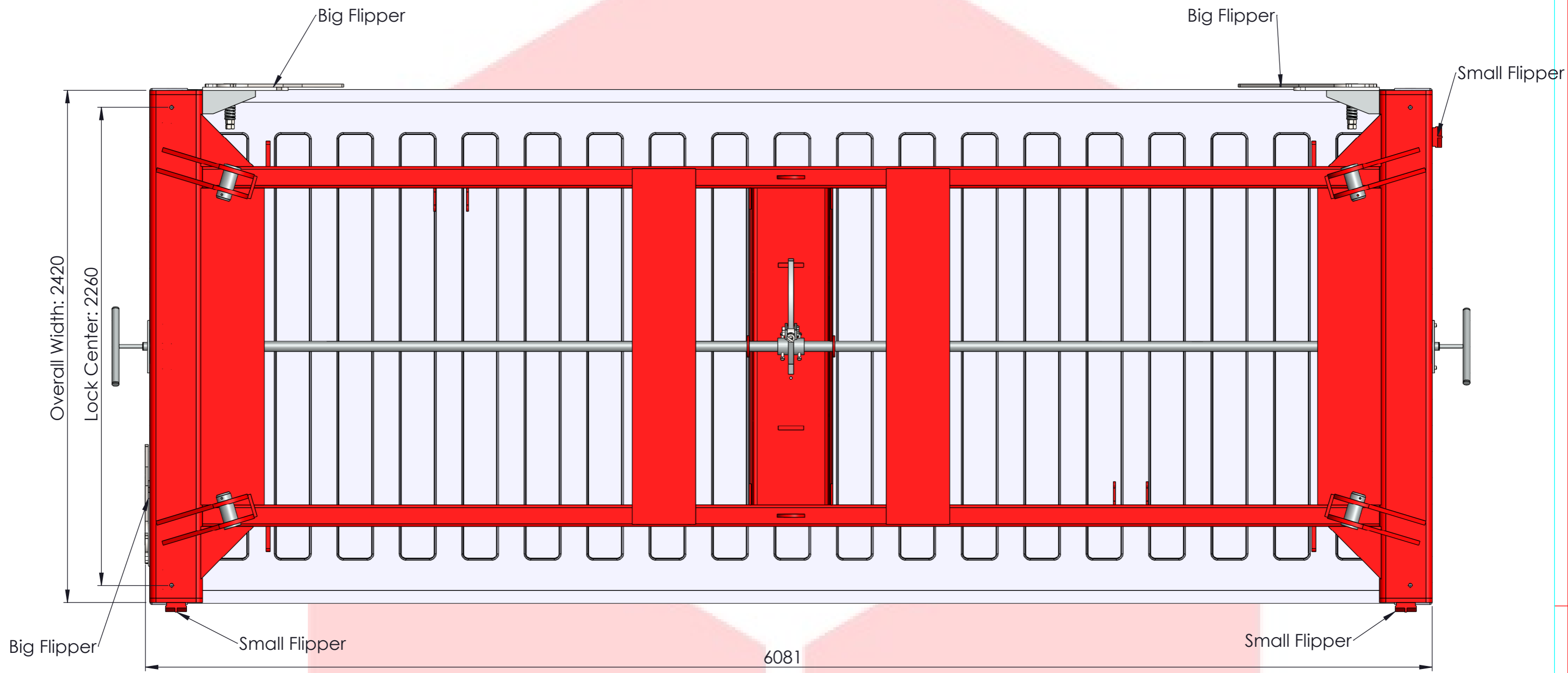

**TOP VIEW**

REVISIONS				DRAWN: Amandeep		DATE: 27-09-2024	
NO.	DATE	SUBJECT	APD	SCALE:	ORDER:	PRINCIPAL:	REV: 3
				1:50			
				CHECKED:	CADNAME: EP106_20FX32		
					PAGE 6 OF 7 PAGES		FORM: A3

DO NOT MEASURE ON THE DRAWING - ALL DIMENSIONS ARE IN MM  
 This drawing can not be copied or given to other persons without written agreement. The drawing remains property of the company PRONK.

32 T Container Spreader  
20 Ft